

Table of contents

A71895 GRAIN SILO D5.3 ASSEMBLY PACK.....	3
A71896 GRAIN SILO D7.5 ADD ASSEMBLY PACK.....	3
ASSEMBLING THE STOCK SILO	4
CONCRETING THE FOUNDATION (SEE FOUNDATION DRAWINGS).....	4
ASSEMBLING THE SILO.....	6
Installing the topmost wall row.....	6
Installing the top rim	8
Assembling the silo.....	8
Installing the roof.....	10
ALTERNATIVE 1 Assembling the roof alongside the silo	11
ALTERNATIVE 2 Installing the centre cone of the roof	13
Assembling the roof on top of the first/topmost wall row	14
Installing the lifting lugs	16
Installing the following wall panels.....	17
Attaching the ready-assembled silo to the foundation.....	21
Installing the manhole hatch in the wall.....	23
Installing the manhole hatch in the roof.....	24
FILLING AND EMPTYING THE SILO	25

Because the standard configuration of the silo delivery varies from country to country, the delivery contents may be different to what has been described in this manual.

Antti-Teollisuus Oy reserves all rights to this manual.

Antti-Teollisuus Oy reserves the right to modify the design of the product without prior notice, even after publication of this manual.

IMPORTANT TO REMEMBER - READ FIRST

1. After taking delivery, open the package and lift the superimposed wall and roof plates apart from each other in order to avoid oxidation. Perform the acceptance inspection in accordance with the packing list.
2. Follow the instructions carefully to ensure that the silo is erected smoothly and swiftly.
3. Remember to use sealing mastic. If the time from delivery to erection is long, store the mastic at an even temperature.
4. The topmost wall row and the roof are joined together by the top rim (see page 8).
5. Follow carefully the assembly instructions for the roof.
6. Use only proper lifting gear that is in good condition for the lifting operations. Do not exceed the maximum allowed loads for the lifting gear. When using a crane, make sure it is suitable and inspected for the assembly work.
7. See the figure at the beginning of the main instruction for the strengths of the vertical supports (page 3). The strengths of the vertical supports are shown on the right side of the image.

A71895 GRAIN SILO D5.3 ASSEMBLY PACK

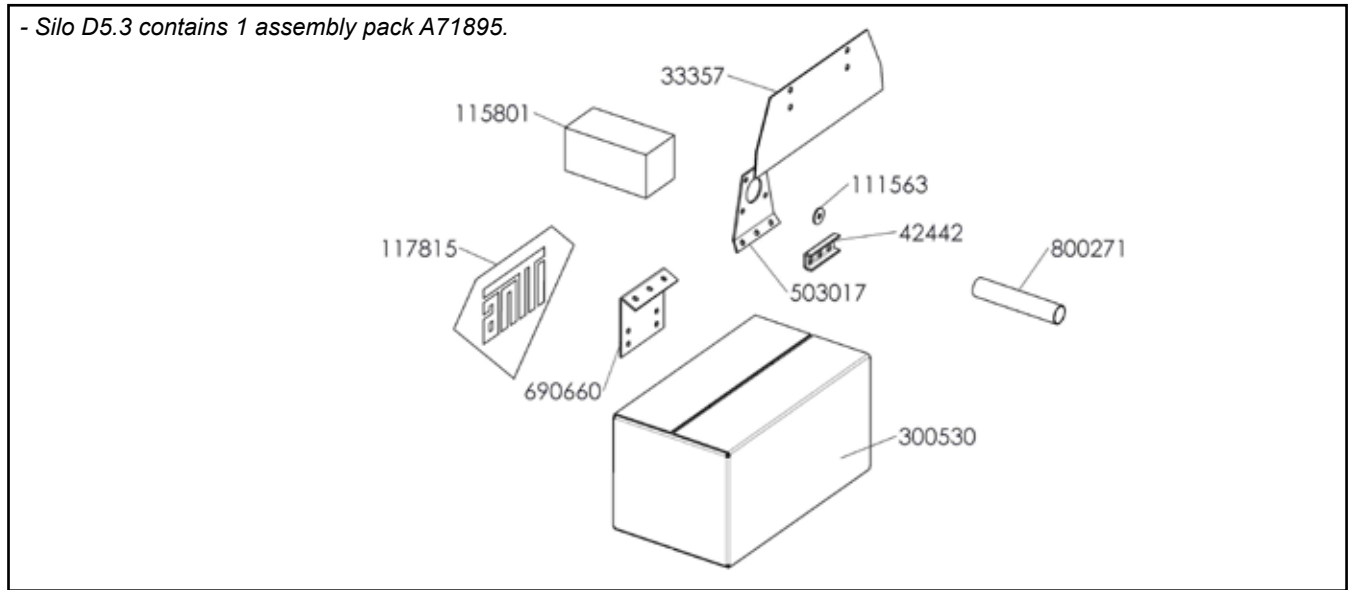

A71896 GRAIN SILO D7.5 ADD ASSEMBLY PACK

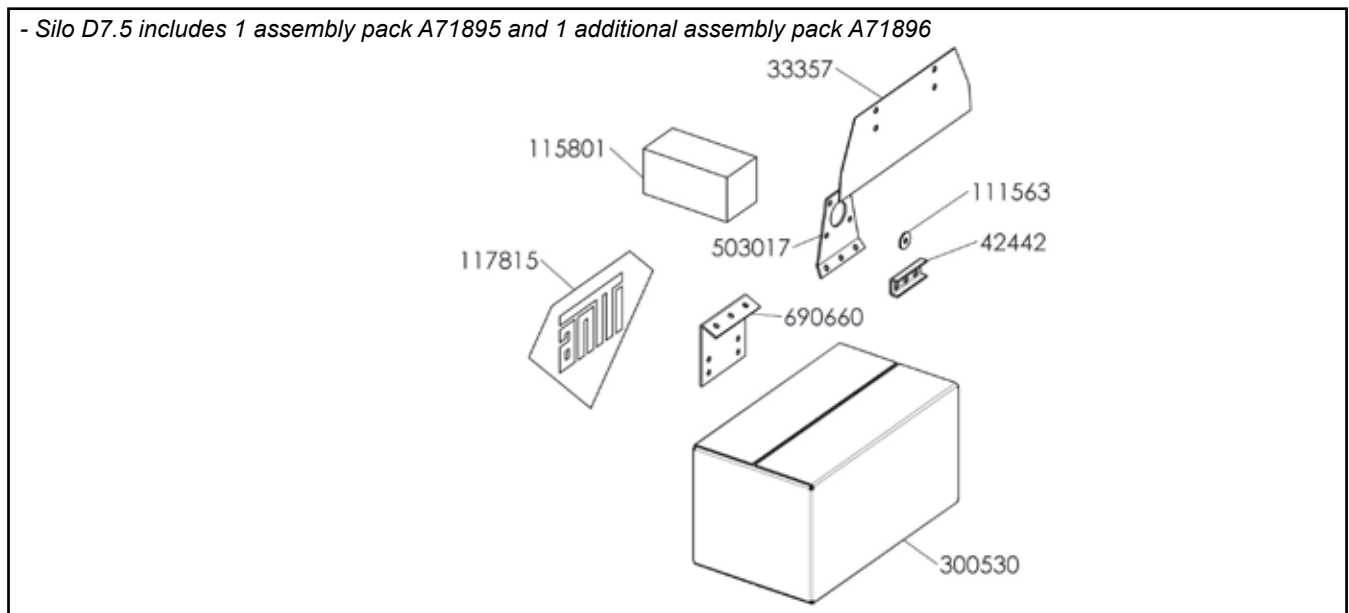

Item	Denomination	A71895 Quantity	A71896 Quantity
300530	CARDBOARD BOX	1	1
42442	ROUND SILO FASTENER M03	32	16
111563	FENDER WASHER M10 D34/D11X3 DIN440R ZN	64	32
503017	DRYER HEATER LU PL4X150X160 30DEG	4	4
690660	ROUND SILO LUG COUNTER-PIEC	4	4
115801	CELL PLASTIC PIECE 100X100X200	16	8
117815	PLATE STICKER TRIANGLE RED/WHITE 292x425	1	1
33357	ROUND SILO SUPP 2X164X438 M03	8	16
800271	MASTIC SEALING/GLUE GREY 310 ML	1	-

ASSEMBLING THE STOCK SILO

Check the contents of the delivery and compare it with the packing list immediately upon arrival, before starting the assembly. Advise the factory of any missing items. The factory is responsible for correcting any defective/incomplete delivery, but it is not obliged to compensate any other costs incurred.

NOTE!

Read the instructions several times before starting the erection in order to memorize the names of the components and the assembly order. To avoid problems, carry out the assembly in stages as described below.

The centre cone of the roof may be charged with a maximum load of 500 kg, caused by the actuators. The conveyor must be supported on the centre cone in such a manner, that the load will not rest entirely on the pipe joint of the cone.

CONCRETING THE FOUNDATION (SEE FOUNDATION DRAWINGS)

Concrete the foundation of the silo to either level or conic shape. If you wish to avoid spadework when emptying the silo, use conic shape. A sharp cone also gives considerable extra space. For example:

Extra space given by a 25° slope

$\varnothing 5,3 \text{ m}$	$\varnothing 7,5 \text{ m}$
9.6 m^3	28 m^3

In the foundation drawings, a 25° conical bottom is used.

The thickness of the foundation slab shall be determined by the size of the silo, the standardised structural drawing and the soil quality at the site. At a low-lying site, where presence of groundwater is likely to cause problems, we recommend raising the height of foundation by laying a sand bed, and concreting the foundation to as high as possible. The foundation of the silo must always be provided with ground frost insulation and subsoil drainage.

Attaching the silo to the foundation, grouting and damp proofing: see the foundation drawings for the silo.

For building permission and other regulations you need to contact your local building authority.

NOTE! *) Tighten all bolts firmly to their prescribed tightness. For M10 bolts of strength class 8.8 the correct tightening torque is 50 Nm. The fastest way to tighten the bolts is to use a pneumatic turn-screw or a cordless drill.

The lifting operations needed for the silo assembly can be performed using a crane, inspected and suitable for assembly work.

The installation of the topmost wall row starts when the concreting of the foundation is completed. The wall row is assembled on top of the foundation.

ASSEMBLING THE SILO

Installing the topmost wall row

Use a mounting punch as an aid. **The long holes shall always remain inside the silo!** See Fig 1.

Fix the wall plates using M10x25 hexagon flange bolts. Place a hexagon flange bolt on the outside and a nut with flange on the inside. If necessary, sealing mastic can also be used for the washers.

Before fixing the wall plates, spread sealing mastic between the hole rows, Fig. 2. The mastic dries quite quickly, so spread it on one plate only at a time. You will need one tube of sealing mastic for two wall plates.

Tighten first the bolts in the bottoms of the wall plate profiles so that they will guide the plates to their correct positions. The tightening should proceed from the centre towards the edges. Before tightening, ensure that the silo stands absolutely straight; otherwise, it will be more difficult to fix the following rows in a level position.

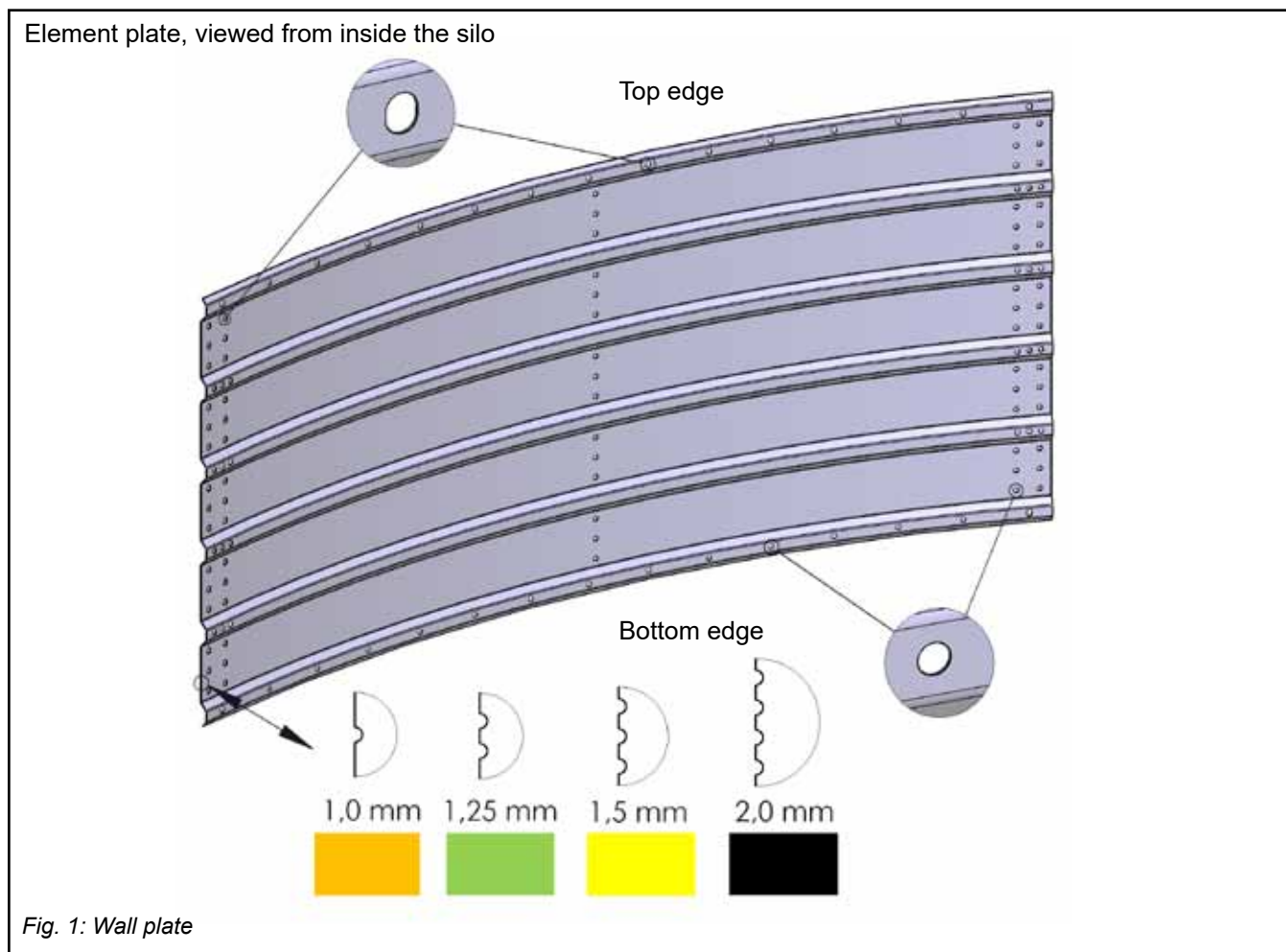

Fig. 1: Wall plate

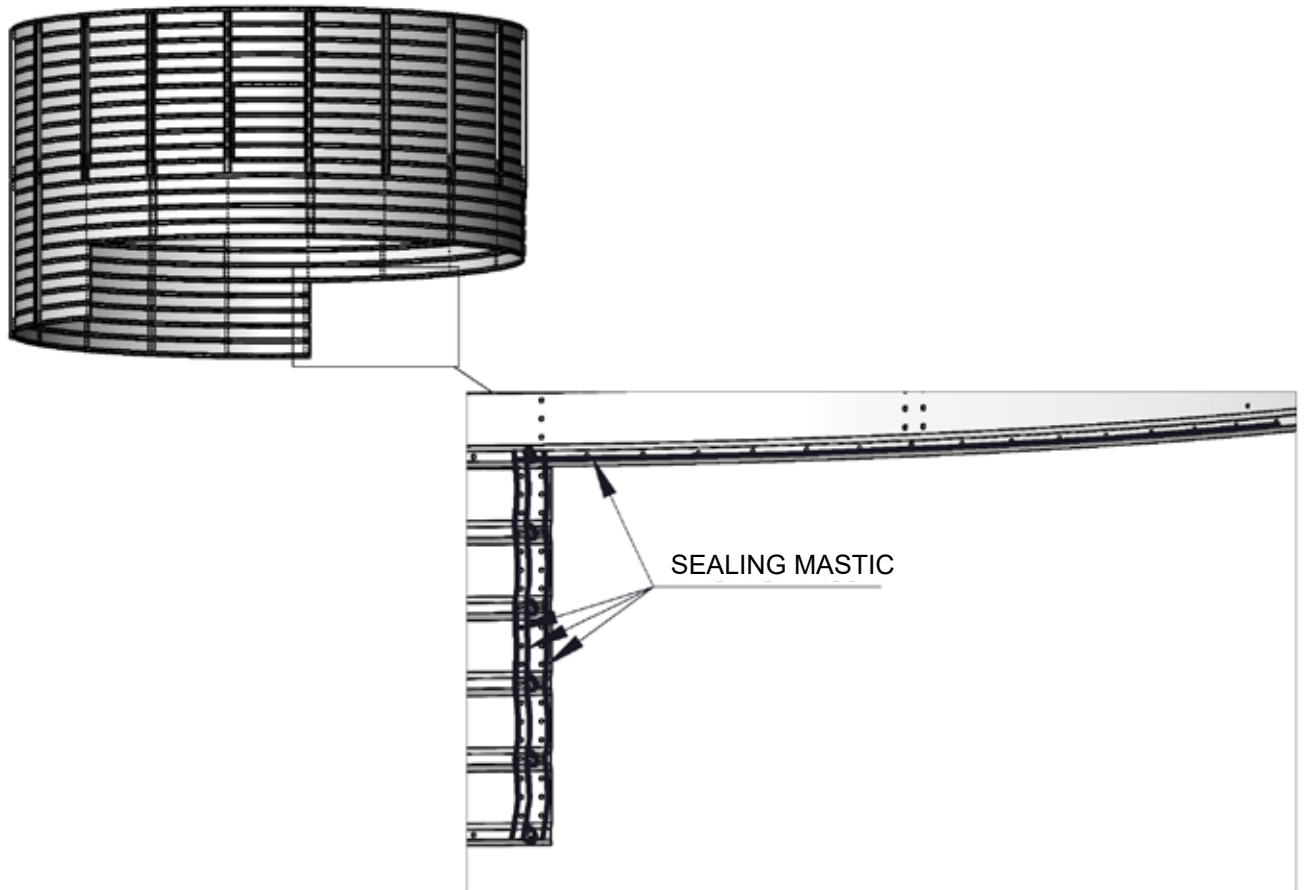

Fig. 2: Spreading sealing mastic on the wall plate. If necessary, mastic can also be used on the flange bolts.

Installing the top rim

After completing the assembly of the top row, install the top rims that enable the roof to be fixed to the wall. See also Fig. 9. The seam of the upper rims is on a head-to-head basis. The upper rims do not overlap.

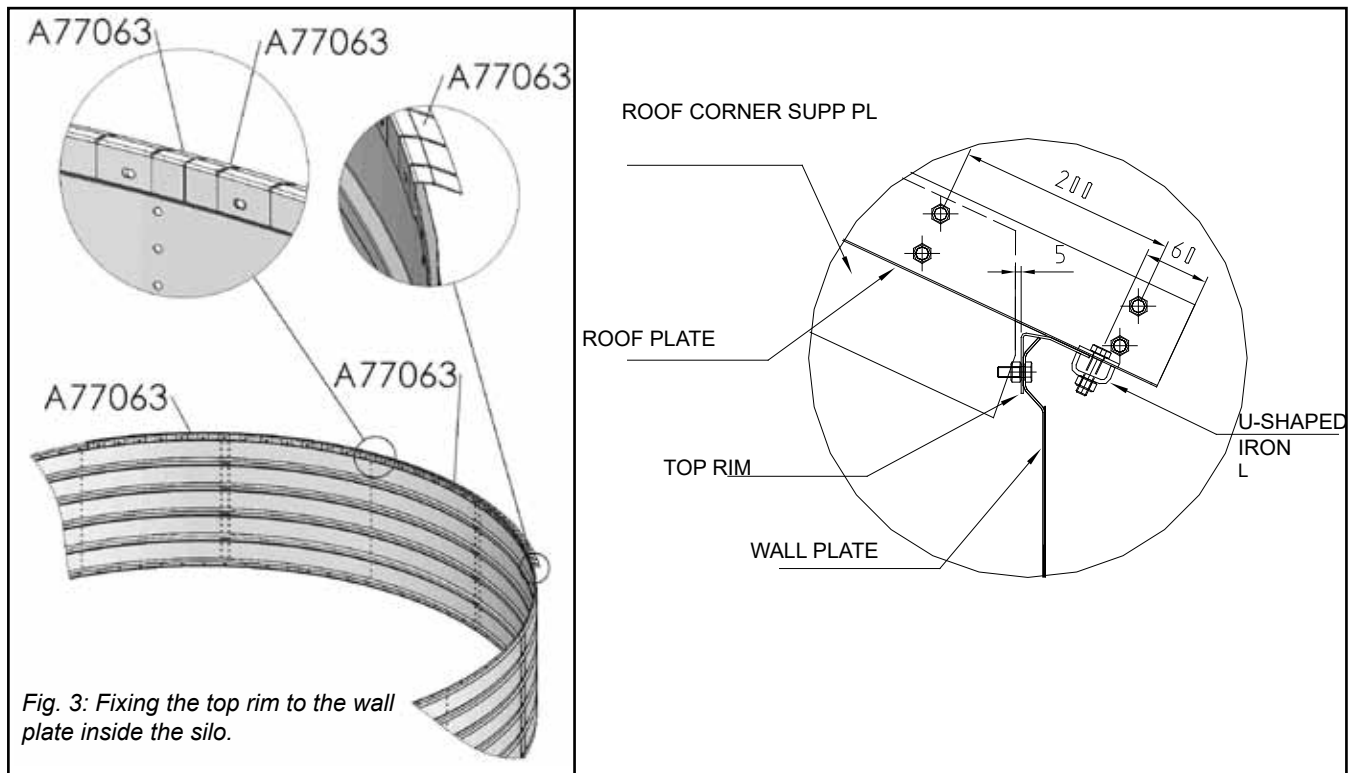

Fig. 3: Fixing the top rim to the wall plate inside the silo.

Assembling the silo

The silo can be assembled using either a crane or five installation jacks.

Choose the assembly method that suits you best from the following four options.

- 1 **If you assemble the roof on the first/topmost wall row and intend to use jacks, you must put the jacks in place before assembling the roof. The silo must be lifted 35 cm from the ground surface using the jacks before assembling the roof on top of it!** See points "Assembling the roof on top of the first/topmost wall row" (page 14)! After that, continue from point "Installing the following wall plates" (page 17).
2. **To assemble the roof on the ground, alongside the silo, using jacks for the assembly, you have to put the jacks in place before lifting the roof onto the first/topmost wall row. You must lift the silo 35 cm from the ground using the jacks before lifting the roof on top of the silo!** See points "Assembling the roof alongside the silo" (page 11)! After that, continue from point "Installing the following wall plates" (page 17).
3. If you are not using jacks for assembling the silo and assemble the roof alongside the silo, see points "Assembling the roof alongside the silo" (page 11) and "Installing the lifting lugs" (page 16)! After that, continue from point "Installing the following wall plates" (page 17).

4. If you are not using jacks for assembling the silo, and assemble the roof on top of the first/topmost row, then see points “Assembling the roof on top of the first/topmost row of the silo” (page 14) and “Installing the lifting lugs” (page 16)! After that, continue from point “Installing the following wall plates” (page 17).

Installing the roof

You can start the installation of the roof as soon as you have completed the first wall row.

Note: Before installing the roof, see the installation instructions for the wall ladder! The placement of wall ladders, roof ladders and resting levels on the wall determines the position of the roof's manhole.

The roof of the silo can be assembled alongside the silo. In this case a crane must be available for lifting the roof. Optionally, the roof can be assembled on top of the first/topmost wall row using a self-constructed support.

Once the roof is in place, jack up the silo evenly, using all the jacks in turns, all the way to the maximum lifting height of the jacks, which is about 120 cm. After that, install one more wall row (see point "Installing the following wall plates", page 17). After having installed the new wall row, lower the silo to the ground and transfer the lifting gear to the panels in the lowest wall row and attach them to the wall in the same way as they were attached to the upper wall row. Repeat the procedure until all the elements of the wall row are in place. If you assemble the silo at a slow pace, always lower it to the ground whenever the assembly work is not in progress, i.e. do not leave it supported by the jacks. Leave out the last plate of the row, the one that is for the moment the lowest so that you can enter the silo without a problem. When assembling the last wall row of the silo, you can use the manhole hatch, that was constructed before the last wall row was completed, as an exit and for taking the tools out of the silo.

The roof can be assembled alongside the silo. In this case a crane must be available for lifting the roof. Optionally, the roof can be assembled on the first/topmost wall row using a self-constructed support.

Roof positioning

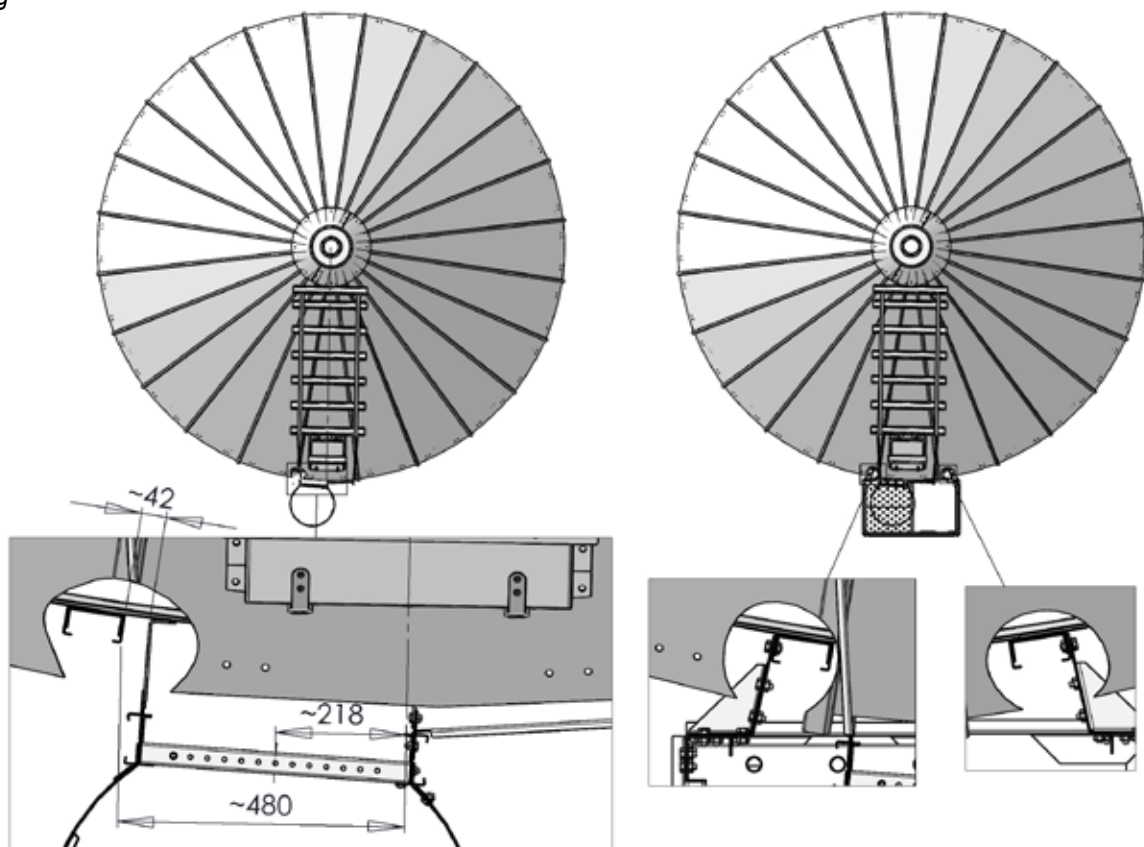

ALTERNATIVE 1 Assembling the roof alongside the silo

The roof can also be assembled on top of the first wall row, see page 14.

Assemble the roof on the ground, alongside the silo, using a temporary support placed on the ground or an auxiliary $\varnothing 1200$ plate that is supported by the crane. The support and the auxiliary plate must be constructed on site of e.g. 3 cm thick veneer plywood. See drawing.

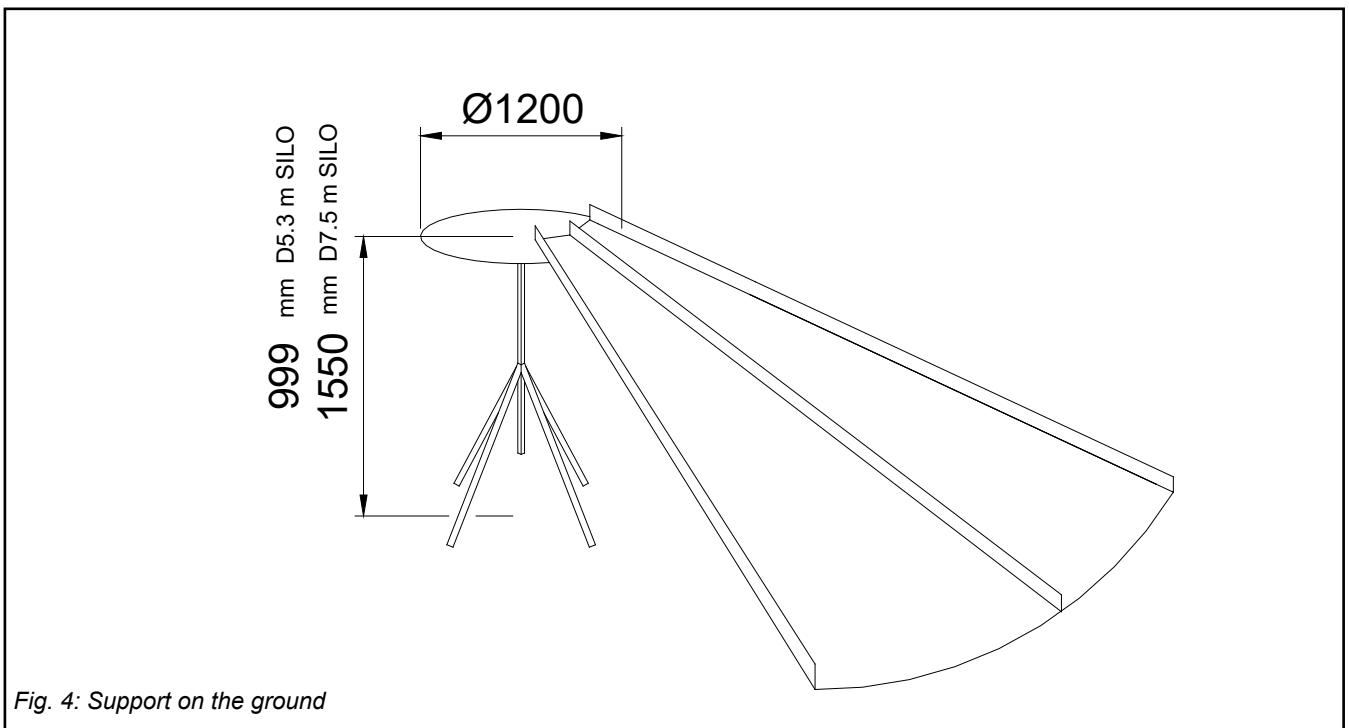

Prop up the support firmly on the ground to prevent it from moving during the assembly of the roof. Put up the roof plates one by one and seal the seams using sealing mastic (you will need 1 tube for the D5.3 silo and 3 tubes for the D7.5 silo)(Fig. 6). Fix the support plates for the roof corners between every other roof section, and in the D7.5 silo, between all the roof sections to the second and the third double holes counted from the outer edge of the roof (Fig. 5). Clamp the roof sections together.

Install the ladder and the roof hatch in the correct direction.

Remember to tighten the bolts!

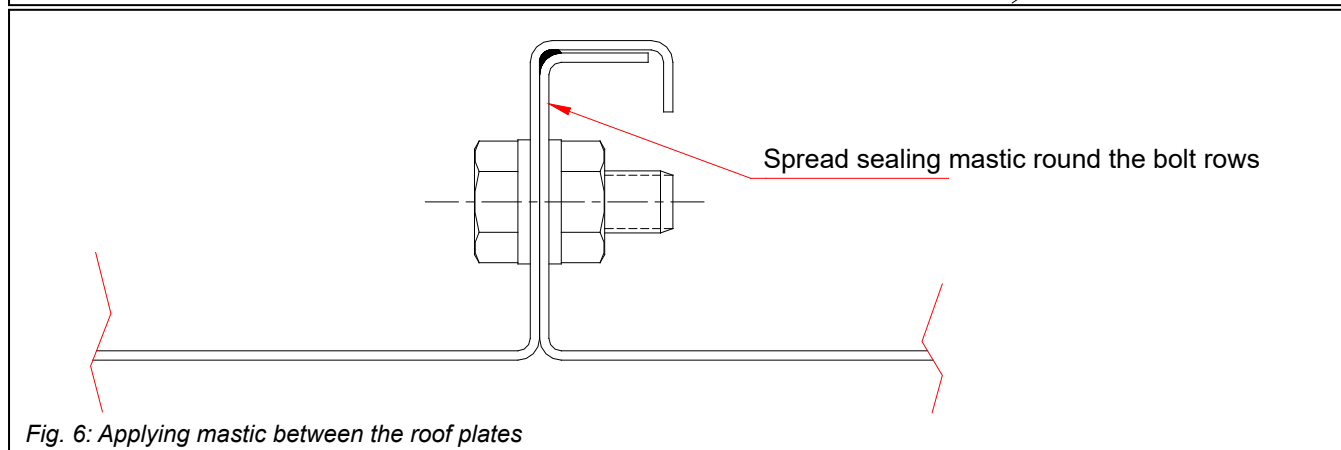
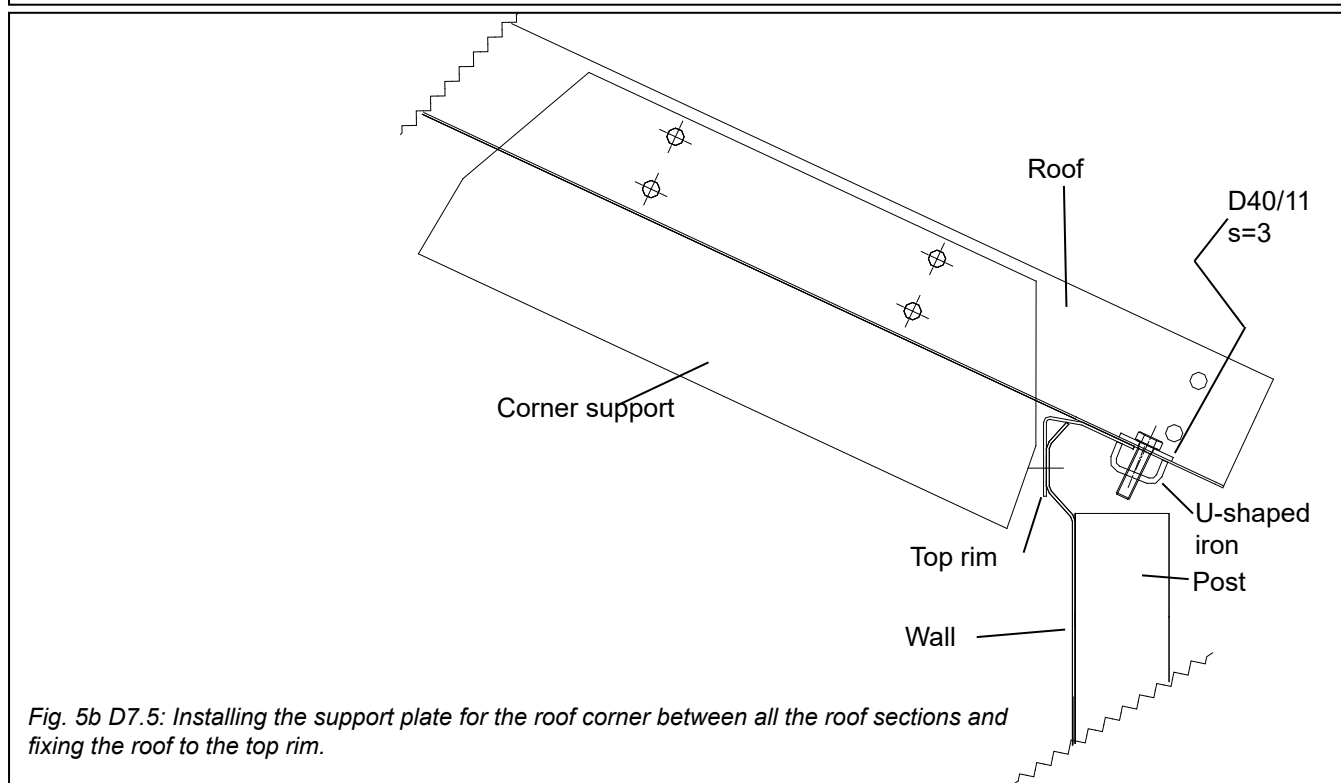
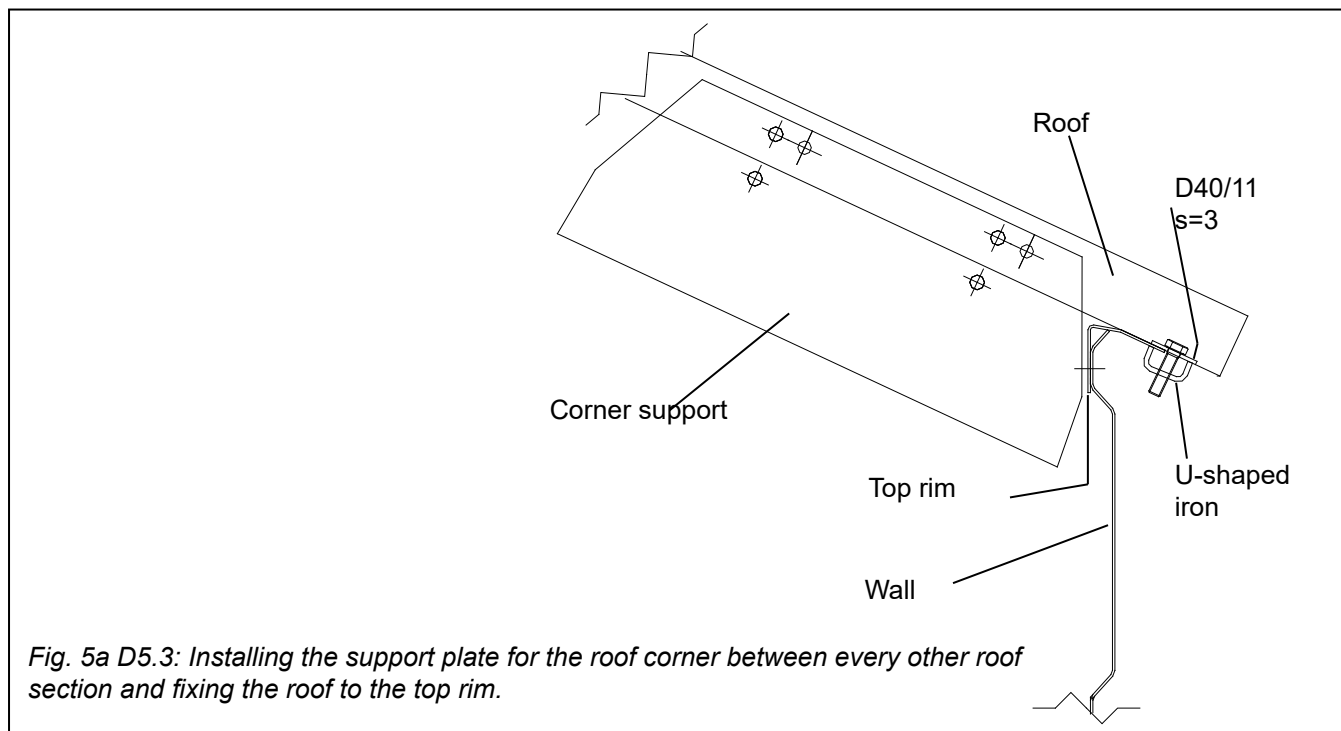

ALTERNATIVE 2 Installing the centre cone of the roof

The centre cone shall not be installed in place until the rest of the roof assembly is completed. **Note! Do not remove the support from under the roof before installing the centre cone in place!** Centre the centre cone in the middle of the opening in the centre before starting the attachment.

Fix the centre cone at the vertical seam of each roof plate using M10x25 bolts (Fig. 7). Fill the opening between the roof and the centre cone with a piece of foam rubber (D5.3 -> 16 pcs, D7.5 ->24 pcs). You may need to cut the foam rubber pieces smaller to make them better fit in the D5.3 silo (~3 cm).

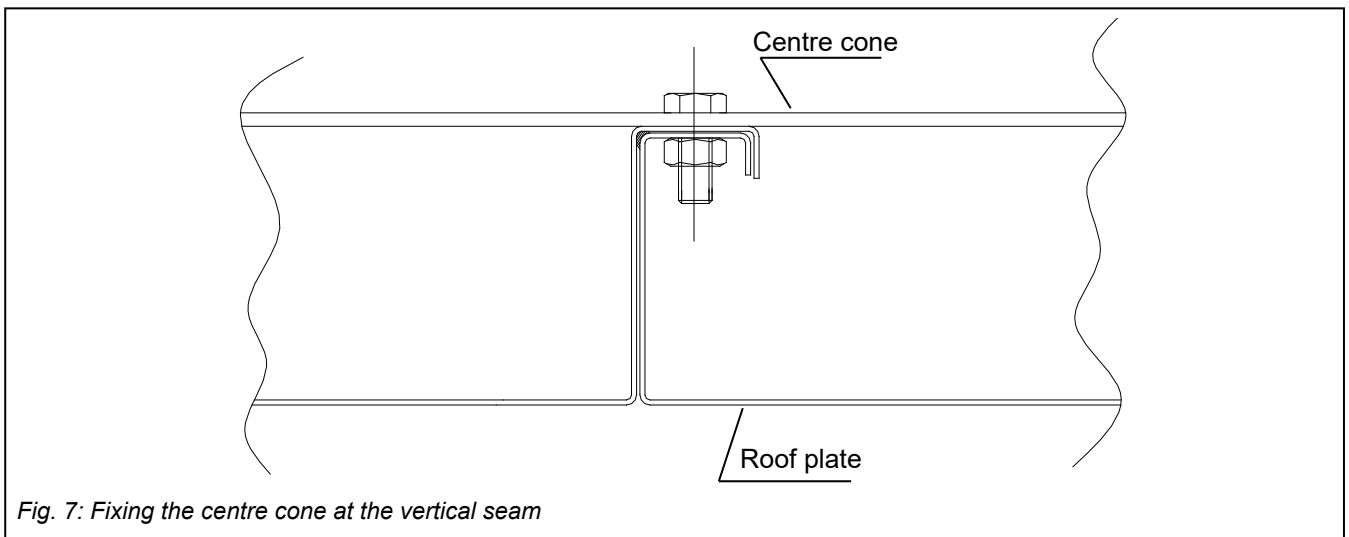

Once the assembly of the roof is completed, lift the roof on top of the first wall row of the silo using the hoist bar as an aid (Fig. 8). The centre cone must be in place before the roof is lifted. Construct the hoist bar on site from, for example, rectangular hollow section of 140x80, L=400 or equivalent and attach a lifting lug to it by welding. Thread the hoist bar under the roof through the opening in the centre cone. Lift the roof carefully on top of the elements. After that, centre the roof with respect to the elements and fix it to the top rim using the U-clamps (2 pcs per roof plate). Make sure to fix one side of the U-clamp to the rim, and the other side to the roof plate (Fig. 5).

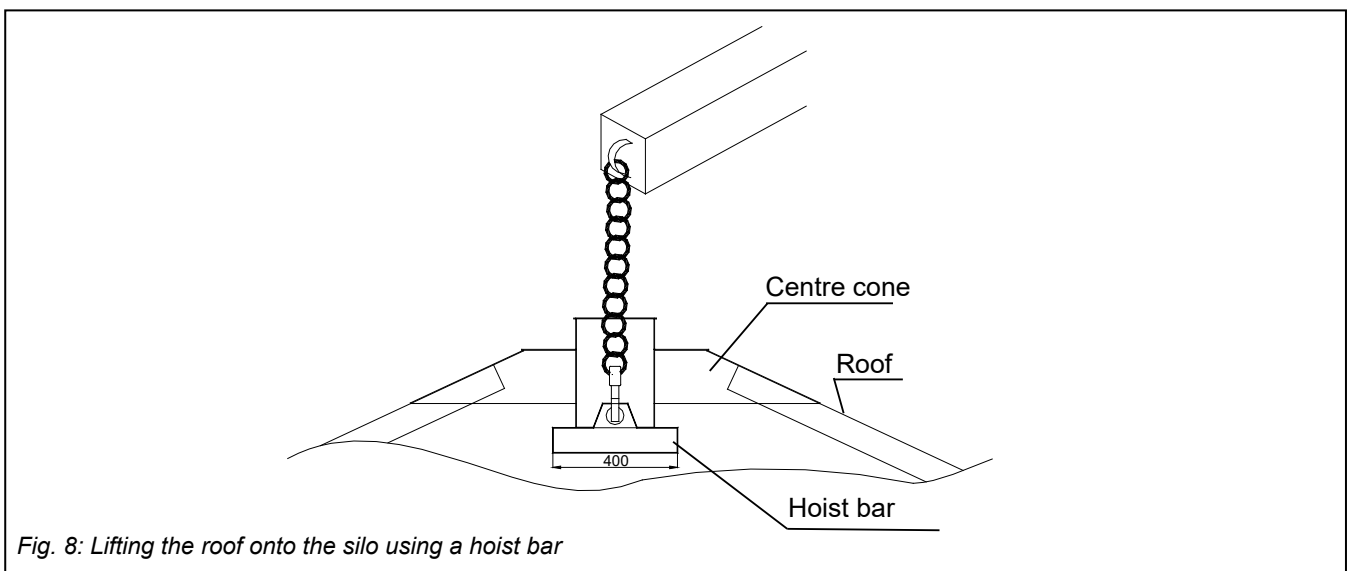

Assembling the roof on top of the first/topmost wall row

Construct for assembly on site a temporary support of, for example, 3 cm thick plywood. (Fig. 9).

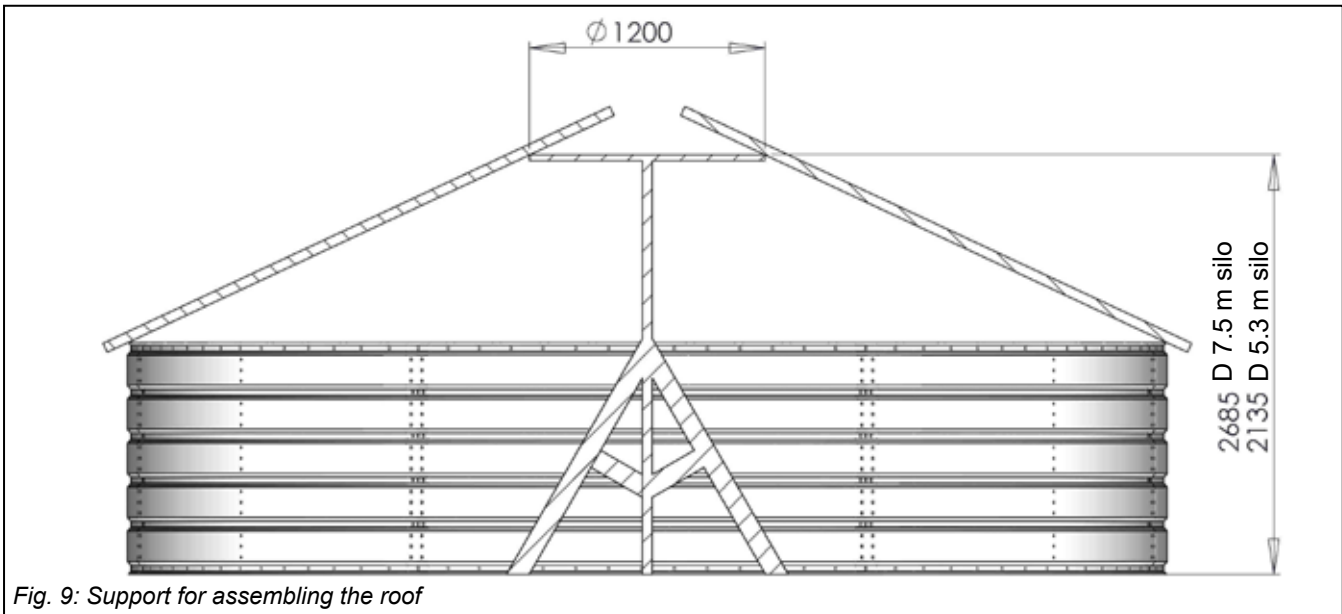

Fig. 9: Support for assembling the roof

Put up the roof plates in place one by one (drawings 1-4) and seal their seams with sealing mastic (you will need 1 tube for the D5.3 silo and 3 tubes for the D7.5 silo).

Place the support plates for the roof corners (item 33357) between the roof sections, in the second and third hole counted from the outer edge of the roof (Fig. 5a and 5b). Only the D7.5 m silo has double holes for attaching the part.

In the D5.3 silo, the support plates shall be installed at every other joint (8 pcs.), and in the D7.5 silo at every joint (16 pcs.).

Clamp the roof plates together, and their lower edges to the top rim of the wall. At the first stage, fix the roof to the top rim using only four U-clamps. Distribute the clamps evenly over the whole circle to enable the roof to be centred easily. Fix the U-clamps using M10x40 bolts. Observe the correct direction for the ladder and the roof hatch.

Remember to tighten all the bolts!

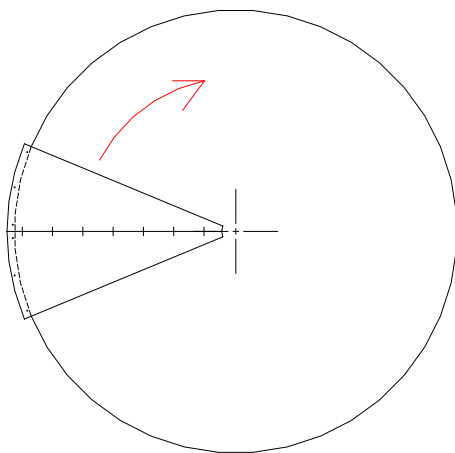

Drawing 1. Fixing the first two roof plates. Do not fix the centre cone of the roof yet.

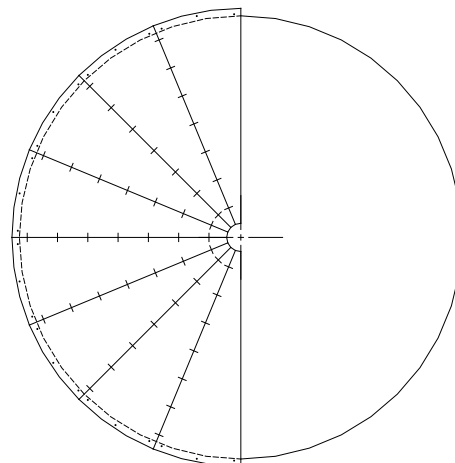

Drawing 2. Fix the roof plates, eight in all, together and to the top rim. Carry out the assembly in clockwise direction.

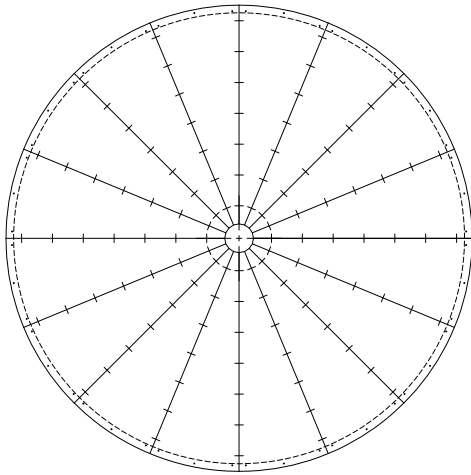

Drawing 3. Match the last seam using a mounting punch and fix the bolts beginning from the lower end.

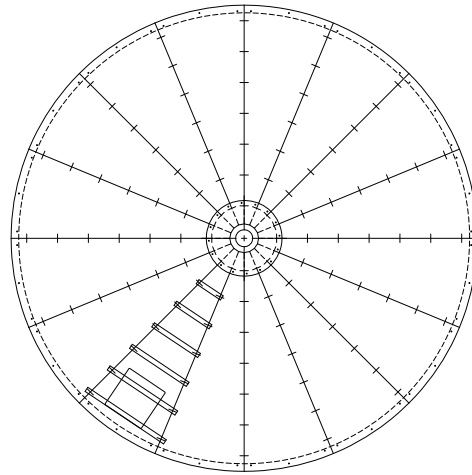

Drawing 4. Fix the roof plates to the top rim. Fix and tighten the centre cone. The roof is now ready. Fix the ladder and the manhole hatch on the roof.

Do not start fixing the rest of the U-clamps for the top rim until all the roof plates have been lifted in place and clamped both together and on to the top rim using the first four bolts. Do not go onto the roof until all the bolts are in place!

Do not install the centre cone of the roof in place until the rest of the roof construction has been completed. Do not remove the temporary support from under the roof until having clamped the centre cone in place. If you remove the support, the roof section may turn over around its tip resulting from the weight of the assembler. The centre cone must be centred in the middle of the centre opening before starting the attachment. Fix the centre cone at each vertical seam of the roof plate using M10x25 bolts (Fig. 7). Fill the opening between the roof and the centre cone with a piece of foam rubber (16 pcs. for D5.3 and 24 pcs. for D7.5). You may need to cut the foam rubber pieces smaller to make them better fit the D5.3 silos (~3 cm). **Note!** It pays to install the roof ladder and the manhole hatch in the roof at this stage, before installing the next wall panels (see Figs. 17).

Installing the lifting lugs

After having assembled the roof and the first/topmost row, install the lugs. Fix the lifting lugs at the joint of the silo roof and the wall element (see Fig.11. Fixing the lifting lug), equidistantly in the middle of the wall element (Fig. 10) using M10x30 flange bolts.

You must drill the holes for the lugs on site. You will need the following number of lugs for erecting the silo: 4 pcs. for the D5.3 and 8 pcs. for the D7.5. **NOTE!** The chains to be used for lifting by the lugs must be sufficiently long so that the angle between the horizontal and the chain will be 45 degrees or more.

Double lifting lugs must be used in 11- and 12-layer silos. **Note:** M10 10.9 hexagon socket bolts for lifting lugs in 11- and 12-layer silos.

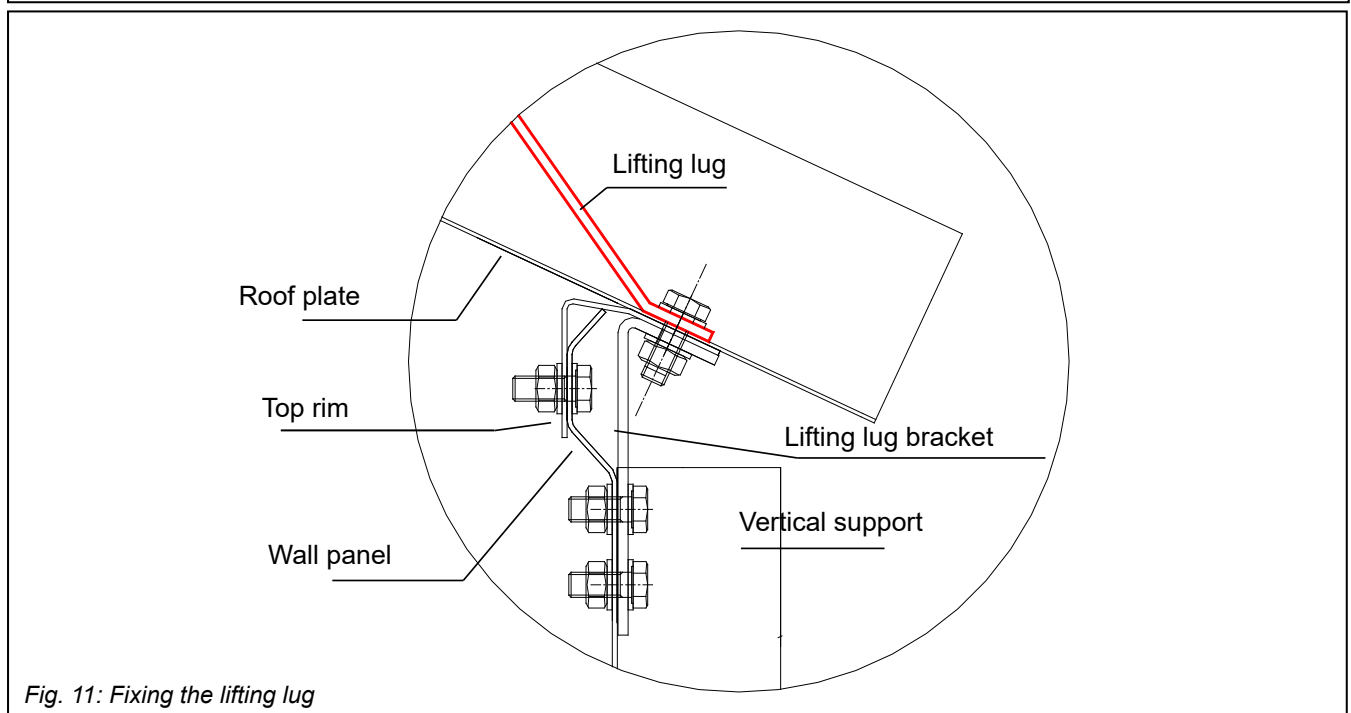
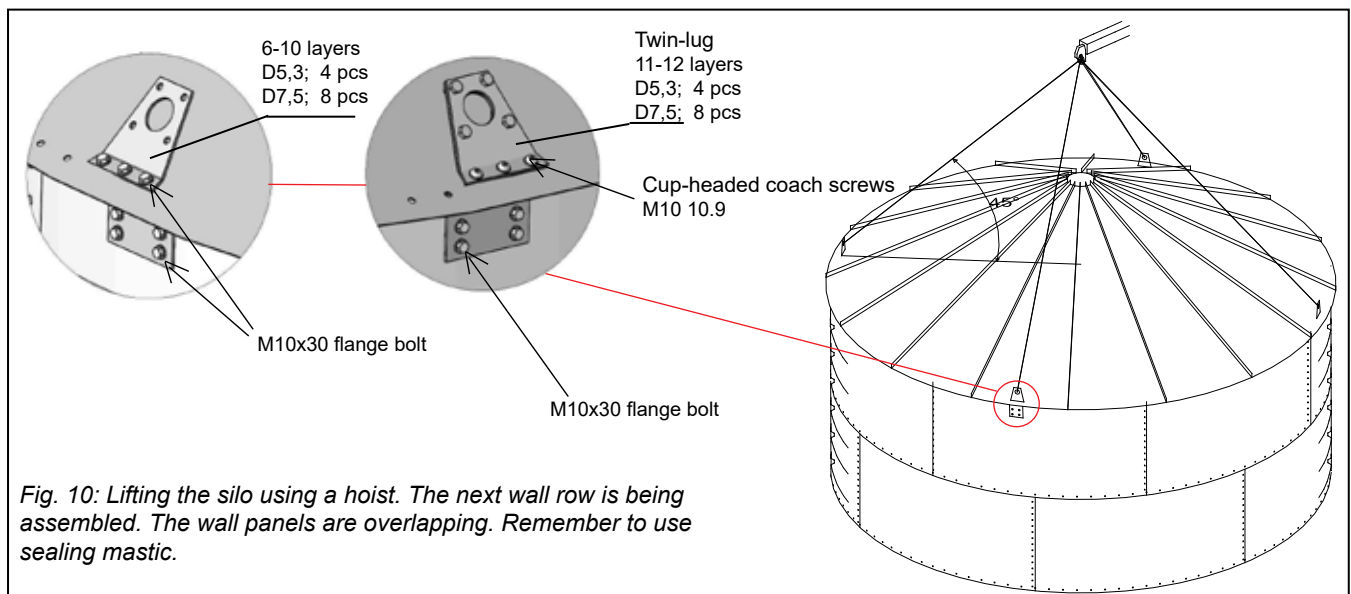

Installing the following wall panels

To install the following wall panels, you must lift up the silo, using either a crane (Fig. 10) or jacks. Lift the silo about 120 cm at a time to enable easy assembly of the wall panels.

After lifting the silo, fix the second wall row from the top to the lower edge of the topmost wall row (see directions in "Assembling the topmost wall row").

The beams must be distributed so that two element rows can be finished at a time. After that, install the respective beams in place. For the strengths of the vertical silo supports, see "Vertical silo supports", see also Figures 12b1 and 12b2. Spread sealing mastic around the holes behind the beams. Do not forget to leave the hole row at the beams without bolts to avoid unnecessary work.

Fix the beams to each other using extension pieces. All the extension pieces are similar even though the material thickness of the supports varies. Tighten the struts to their prescribed torque (50 Nm for M10 flange bolts). You cannot place the extension pieces between the vertical supports afterwards, so put them in place during assembly, before installing the next strut on the underside. The vertical seams of the wall rows fall in the middle of the plates in the upper row (Fig. 13).

Install the elements so that the middle hole row of the wall panel on the upper side always aligns with the innermost bolt hole row on the right-hand side of the wall plate to be installed, that remains visible. The installation of the elements must proceed clockwise. The supports shall be installed in every row. Observe that the thickness of the supports varies between the rows.

See the figure at the beginning of the main instruction for the strengths of the vertical supports in the silo (page 3). The strengths of the vertical supports are shown on the right side of the image.

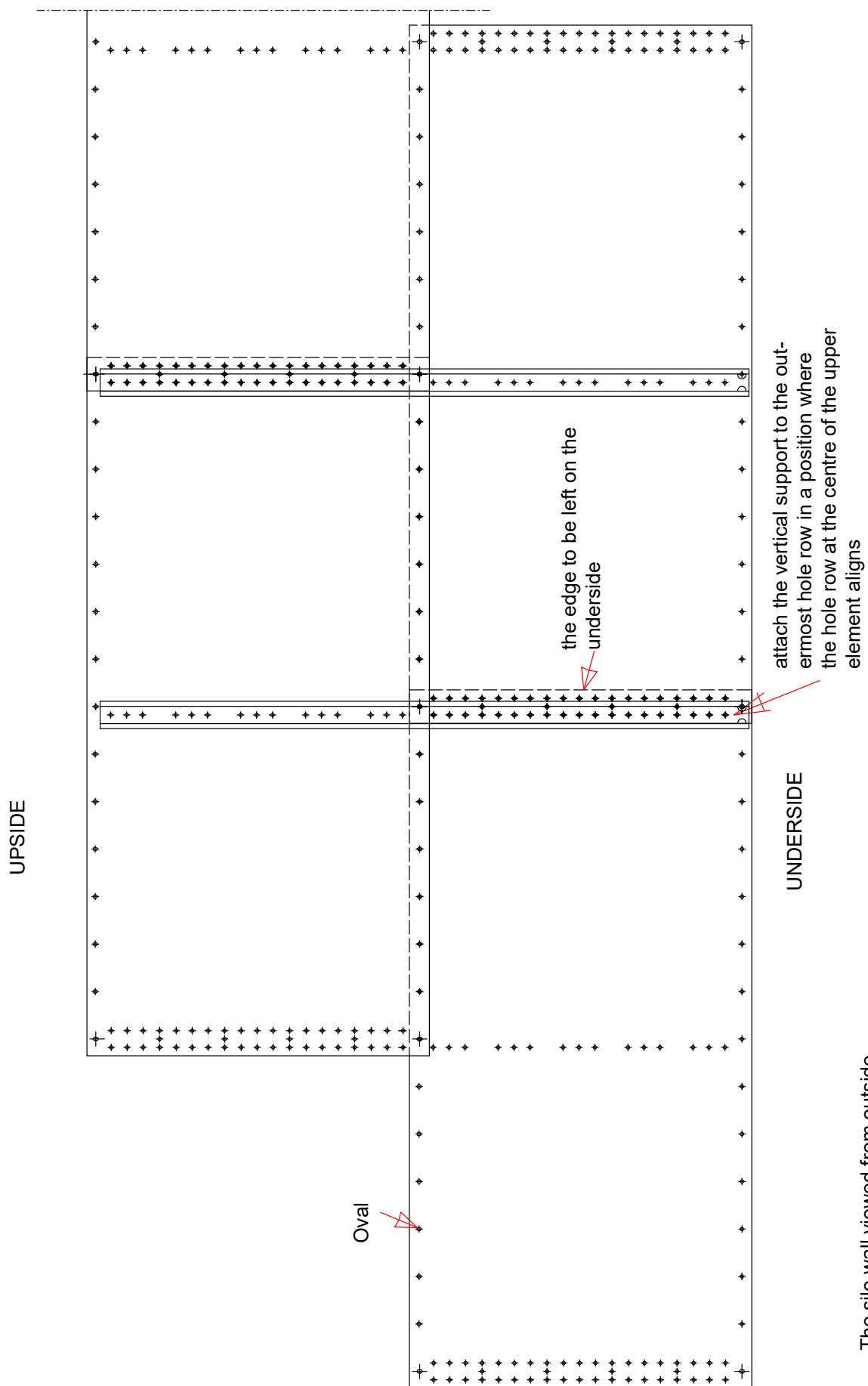

Fig. 12b1: The silo wall viewed from outside

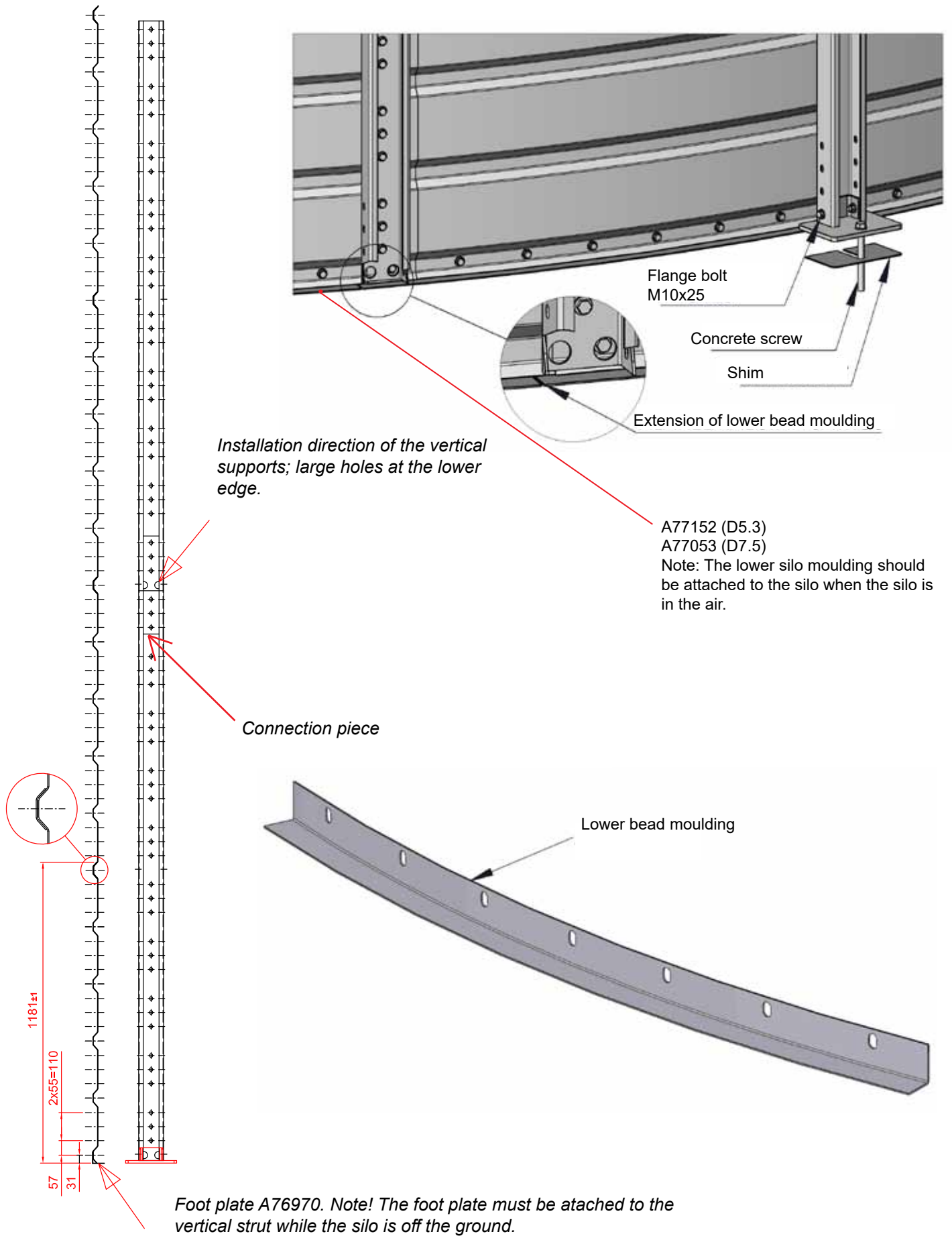

Fig. 12b2: The support viewed from the front.

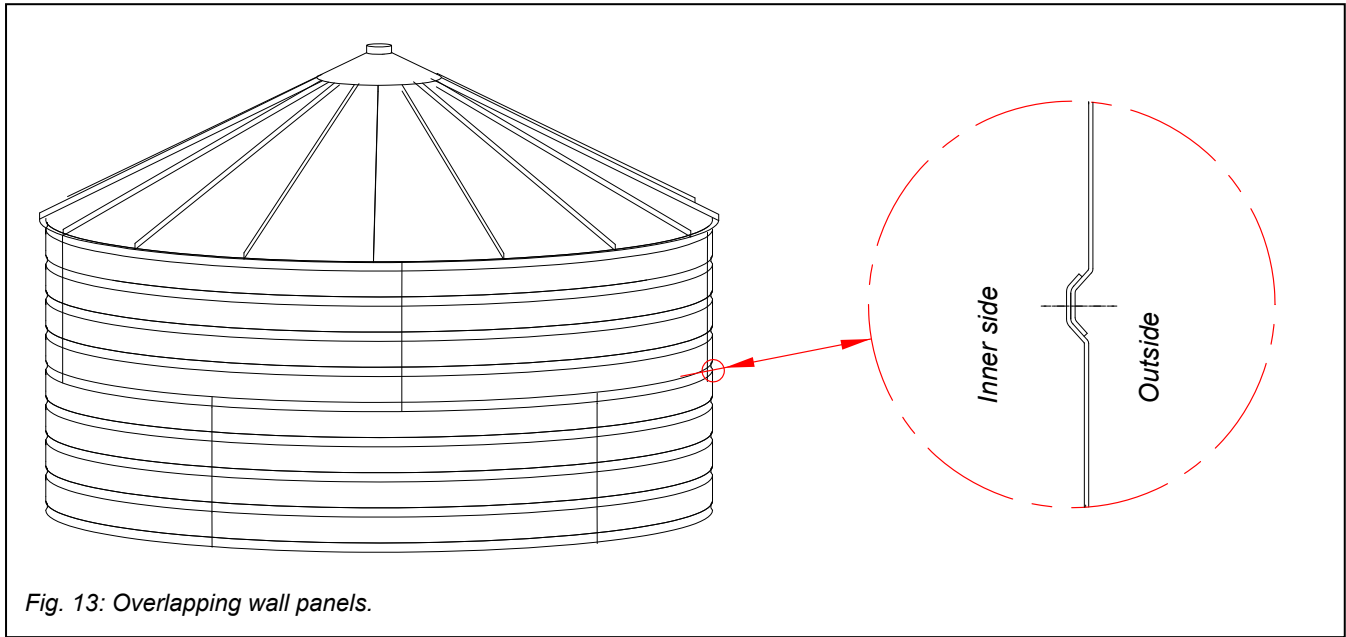

Fig. 13: Overlapping wall panels.

Note! Be careful not to mix up supports of different material thickness. To avoid mixing up the supports, keep them in different stacks.

Attaching the ready-assembled silo to the foundation.

As soon as all the wall plates are in place and the assembly of the silo is completed, lower the silo onto the concrete foundation. If the height is not correct, use shims between the foot plate and the concrete. **Note! The foot plates must be attached to the vertical struts of the silo before the lowering!**

Attach the foot plates to the concrete foundation by using M14x150 concrete screws, 1 anchor/plate. Drill a D14 hole, 155mm deep for the concrete screws. Clean the drilled hole before installing the concrete screw (*Ensure that the concrete foundation has become sufficiently hard after the casting to provide firm attachment of the concrete screws*).

Concrete screws are included in the basic bolt package delivery for the silo.

Seal the lower edge of the silo jacket using lower bead moulding. Attach the lower bead moulding to the silo jacket by the hole row in the jacket using M10 bolts. Apply butyl compound between the lower bead moulding and the concrete as well as between the lower bead moulding and the silo jacket to achieve sufficient tightness.

If the silo has a flat bottom or is fitted with a concreted cone, insulate the contact surface between the base concrete and the surface concrete by applying a damp-proof course. The damp proofing with bitumen must be carried out before concreting the surface. The hot-galvanised metal parts, which remain under the surface concrete, must also be damp-proofed with bitumen. Fresh zinc, which has not been passivated yet, reacts with the ingredients of the concrete, and as a result, causes corrosion. For this reason, the parts covered by concrete must be protected. Refer to the standardised structural drawing and the details in it for more detailed information about the objects to be protected. Note! The insulation with bitumen and the surface concreting must be carried out across the entire concreted foundation. No grout is required on the steel conical silo.

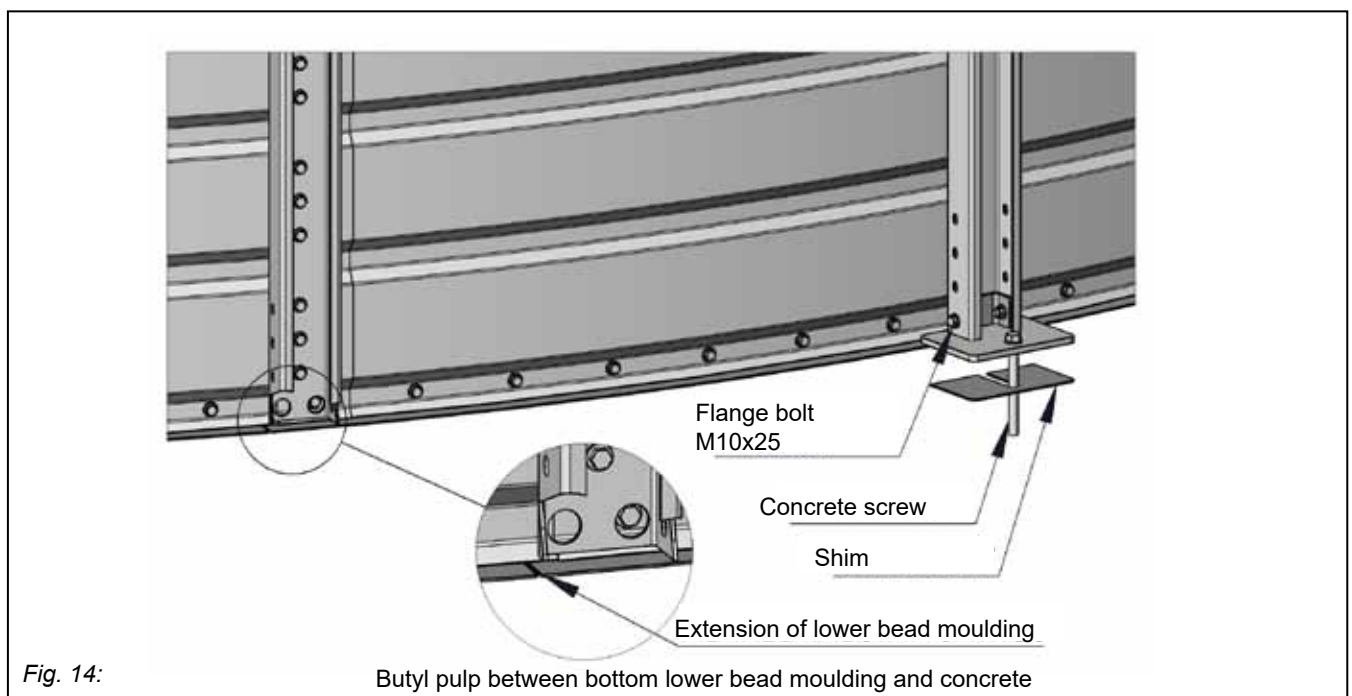

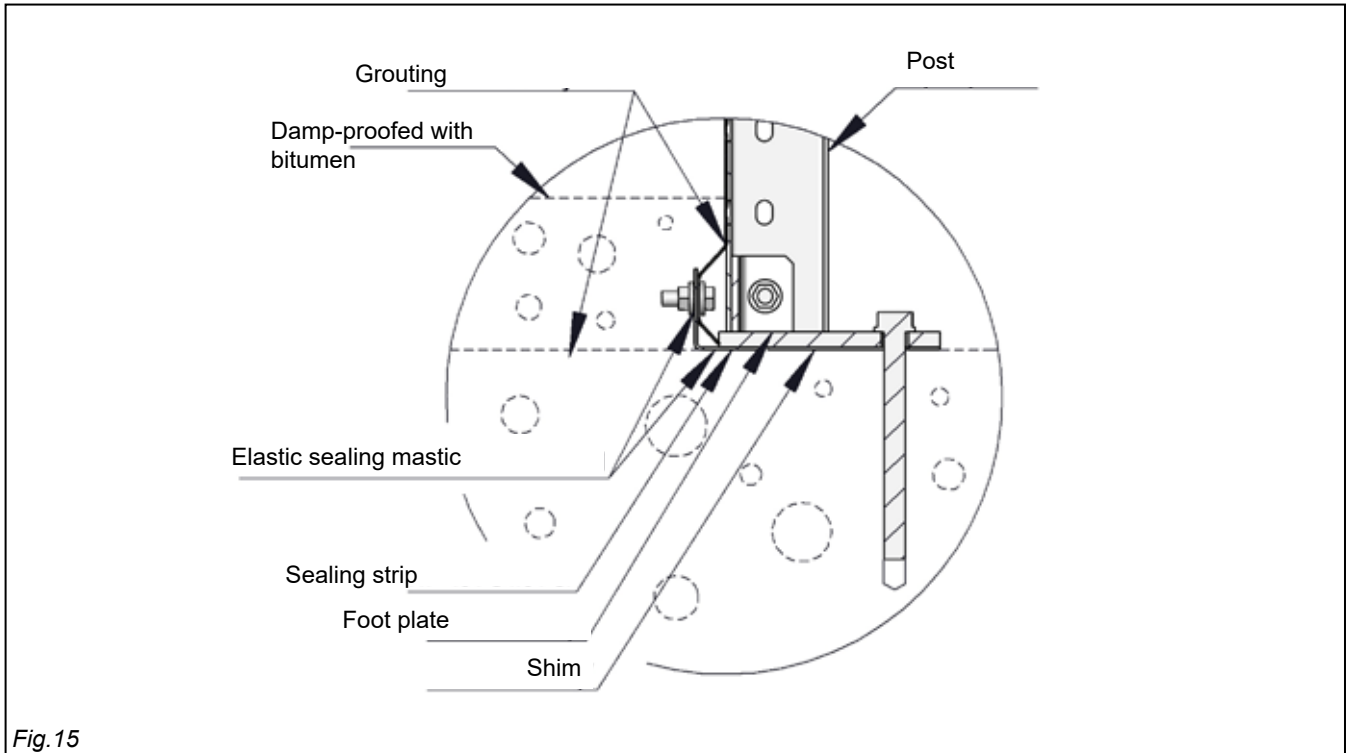

Fig.15

Installing the manhole hatch in the wall

Install the manhole hatch on the inside of the silo wall between the supports in a suitable place with easy access. An opening has been made ready for the manhole hatch in one of the elements.

In the D7.5 silo with level bottom, the hatch shall be installed in the third wall row and in the silo with conic bottom, it shall be installed in the second wall row (See Fig. 18).

In the D5.3 silo with level bottom, the hatch shall be installed in the second wall row and in the silo with conic bottom it shall be installed either in the first or in the second wall row.

The joint between the silo jacket and the manhole hatch frame shall be sealed with butyl mastic, which is applied between the manhole hatch frame and the silo flange.

See the steel cone installation instructions pages for the placement of the manholes of the silo with steel cone.

The manhole is mounted on a wall element with a manhole opening. The material strength of the gaped element is 1.5mm.

Note: The manhole must not be fitted in a wall element that is thinner than 1.5mm.

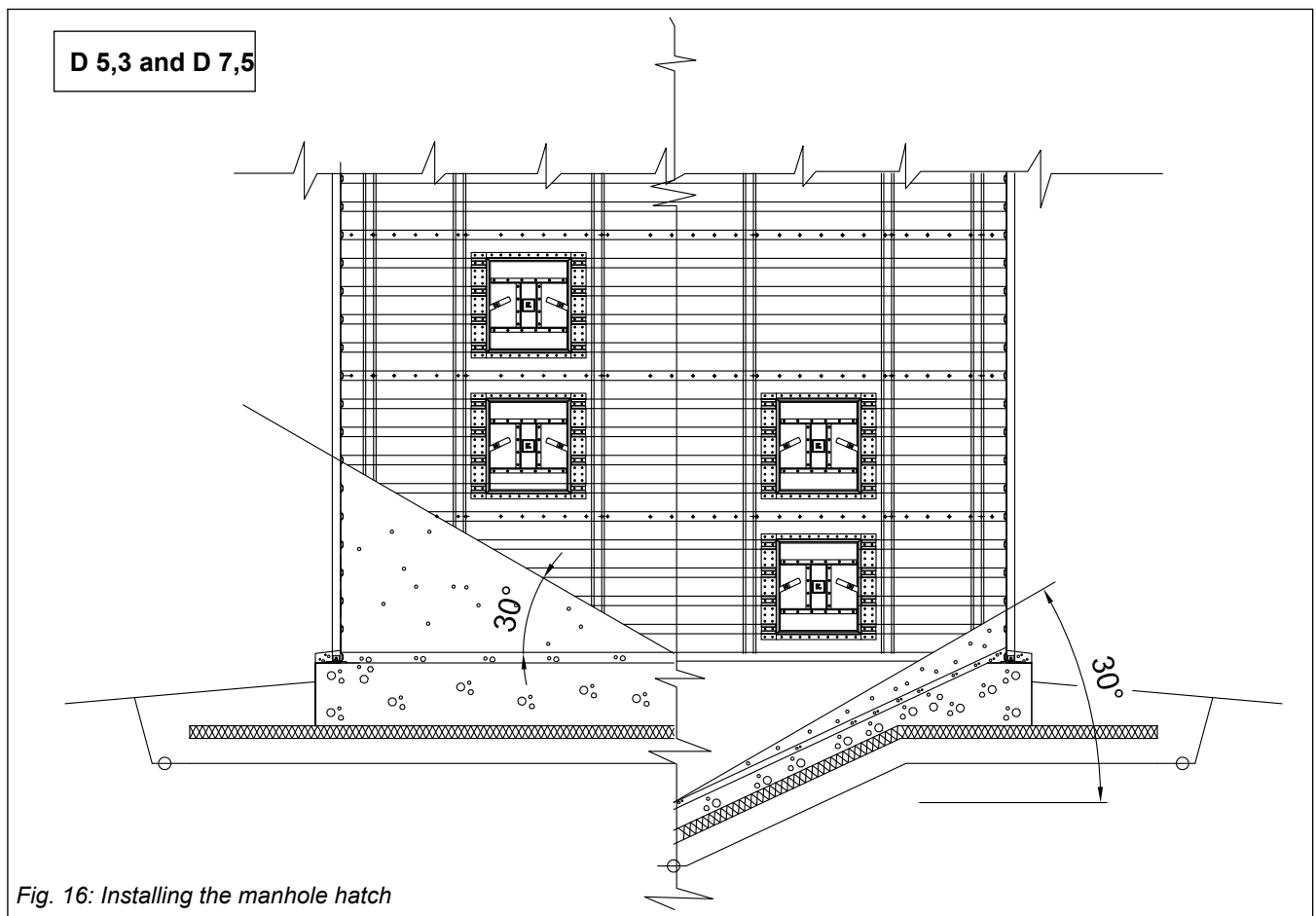

Fig. 16: Installing the manhole hatch

Installing the manhole hatch in the roof

For safety reasons, the roof hatch shall be installed under the ladder in the same roof section with the roof ladder.

The roof section package includes one different section with ready holes for the manhole hatch.

Fix the hatch using M10x25 bolts and apply sealing mastic that contains glue (Fig. 17).

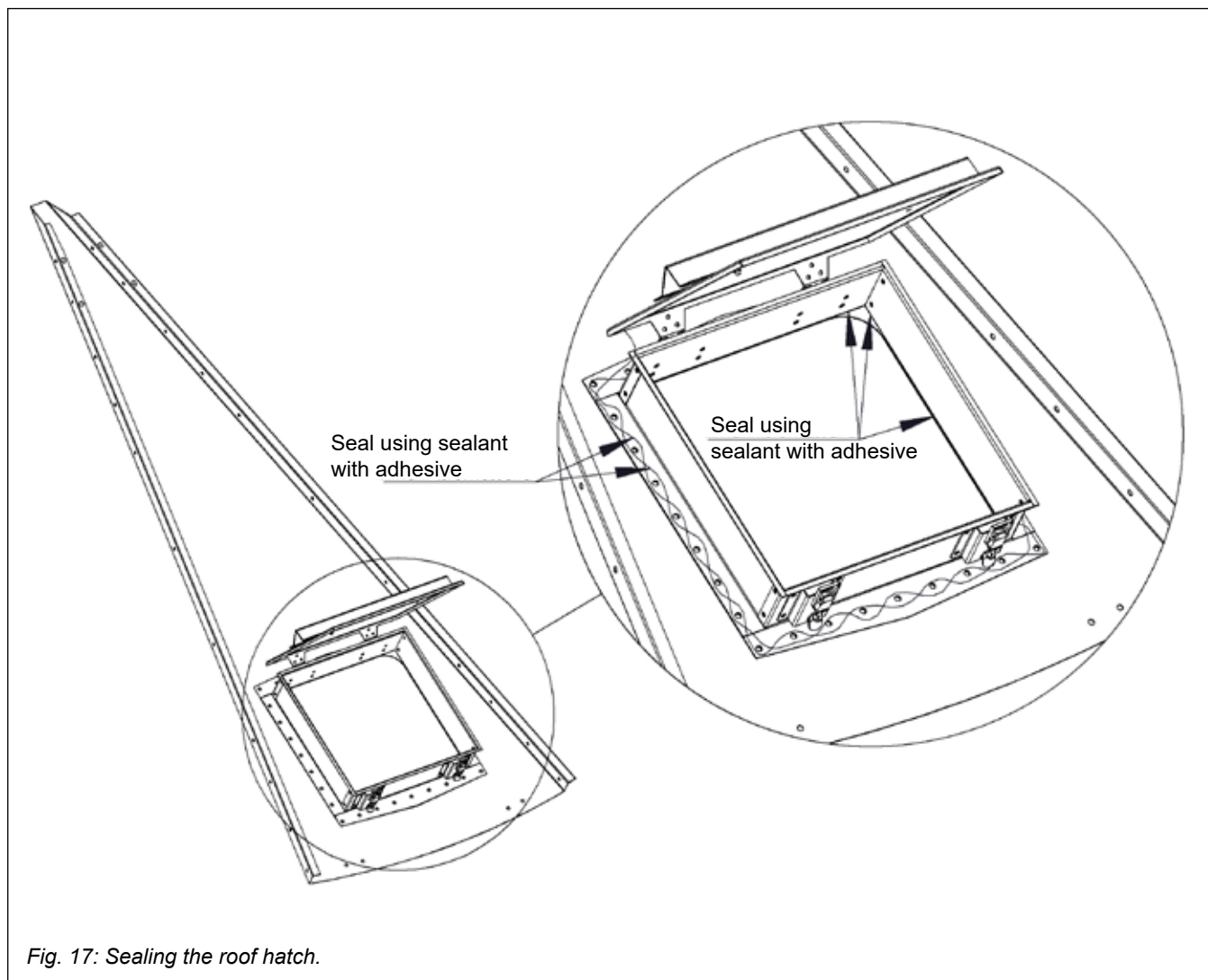

Fig. 17: Sealing the roof hatch.

Seal the joint between the manhole hatch frame and the roof section using sealant with adhesive. Apply a run of sealant with adhesive around each hole between the roof section and the manhole hatch frame. After wrenching the manhole hatch tight, seal the lower edge of the roof hatch frame by applying sealant with adhesive on the inside, around the whole frame.

FILLING AND EMPTYING THE SILO

When the silo is full, its integrity is based on even loading. It is, therefore, very important that the grain will spread evenly inside the silo during the filling and emptying phases. This helps prevent uneven loading. In the centre cone A76021 of the roof, which is the standard feature of the silos, the silo is filled through the filling opening, where the D250 vertical pipe directs the grain to the centre of the silo.

The projecting part of the pipe is formed to take a quick-fastener that enables connecting of other conveyor pipes.

Using a blind centre cone A76026 in the silo roof (not a standard feature)

When a blind centre cone is used, it must be ensured that the silo is filled at the centre. Make a filling opening in the centre cone on the erecting site by cutting an opening in the blind plate. As required, shorten the tip part of the roof sections at the erecting site at the filling opening (this must be done for the D5,3 silos). If necessary, the gap between the roof section and the centre cone must be tightened using larger pieces of foam rubber than what are included in the delivery.

