

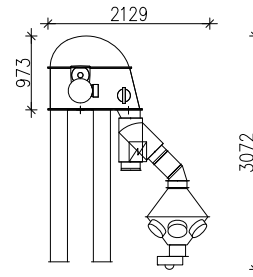

# Antti Mixflo MF3 / E-elev / P-250

2- tj/way + 6- tj/way



6- tj/way

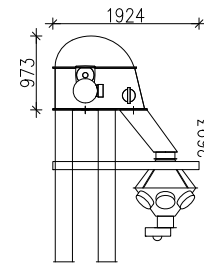

3- tj/way

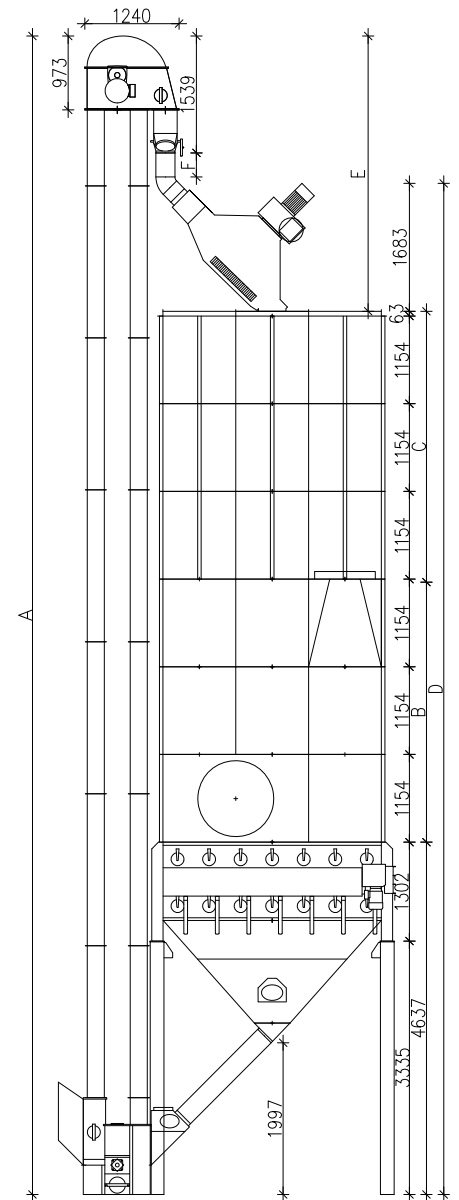

A:	Elevaattorin mitta	Elevator height
B:	Lämpökennojen mitta	Dimension of drying sections
C:	Yläsäiliöt + kansi mitta	Dimension of top sections + roof
D:	Koneen kokonaiskorkeus + esipuhdistin mitta	Total height of dryer + pre-cleaner
E:	Elevaattorin yläpään ja kannen välinen mitta	Dimension between the elevator top and the dryer roof
F:	Suoran putken pituus välillä 3-tiejakaja - valukäyrä	Straight pipes length between 3-way divider - cast elbow

Jalustatyyppi /Base type	3W
jalusta / base m <sup>3</sup>	3,00
kenno / section m <sup>3</sup>	4,68
yläsäiliö / top section m <sup>3</sup>	6,64

P 250 esipuhdistin / pre-cleaner

3W	500 mm ilmapäädyt / air channel ends						1000 mm ilmapäädyt / air channel ends				
	22	23	33	34	44	45	54	55	65	75	85
V [m <sup>3</sup> ]	25,3	31,8	36,5	43,0	47,6	54,1	52,3	58,8	63,5	68,2	72,8
A 3- tj /way [mm]	12700	14200	15200	16200	17200	18700	18700	19700	20700	22200	23200
A 6- tj /way	13700	14700	16200	17200	18200	19700	19700	20700	21700	23200	24200
A 2- tj/way + 6- tj /way [mm]	14200	15200	16200	17700	18700	19700	19700	20700	22200	23200	24200
B [mm]	2308	2308	3462	3462	4616	4616	5770	5770	6924	8078	9232
C [mm]	2371	3525	3525	4679	4679	5833	4679	5833	5833	5833	5833
D [mm]	10999	12153	13307	14461	15615	16769	16769	17923	19077	20231	21385
E 3- tj /way [mm]	3431	3777	3623	3469	3315	3661	3661	3507	3353	3699	3545
E 6- tj / way	4431	4277	4623	4469	4315	4661	4661	4507	4353	4699	4545
E 2- tj/way + 6- tj /way [mm]	4931	4777	4623	4969	4815	4661	4661	4507	4853	4699	4545
F 3- tj /way[mm]	124	470	316	162	8	354	354	200	46	392	238

500 mm ilmapäädyt / air channel ends

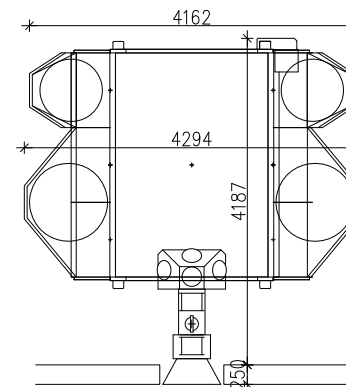
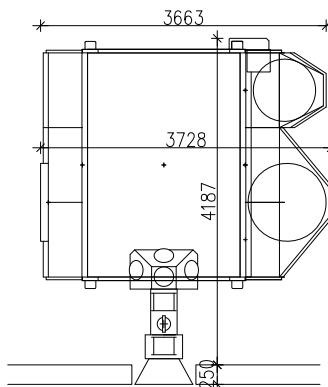
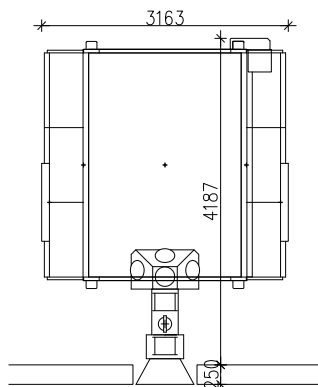
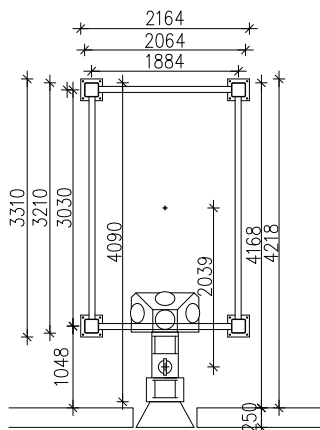

1000 mm ilmapäädyt / air channel ends

