



114552 1 -stage axial fan * 17,2 kW ø710mm**

- Fits directly to Antti dryers air channel
- Low energy consumption
- No vibration
- Easy to install; no additional support needed
- Air qty / back pressure 34 500 m³/h / 800Pa (50 Hz)
- Include fire thermostat and suction bell
- Control always a frequency converter
- Installation position for fire thermostat and temperature sensor
- Weight 108kg

Extra equipment:

- A75893 Matching part axial fan / SR D800
- 114556 Axial fan damper
- 114557 Axial fan instalation legs

800Pa	17,2 kW	Current
50 Hz	104 dB	31,5 A
45 Hz	103 dB	25,9 A
40 Hz	98 dB	20,9 A

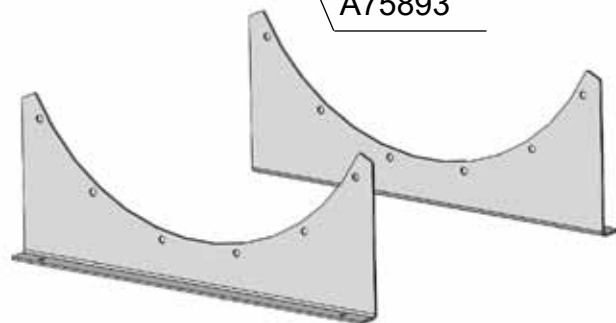
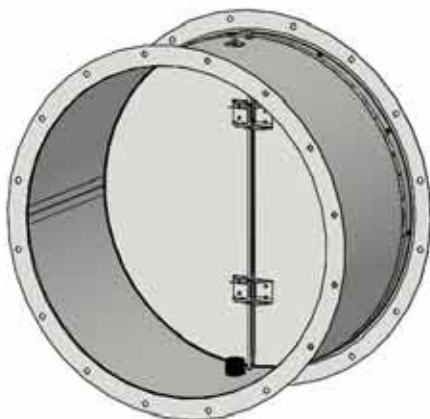
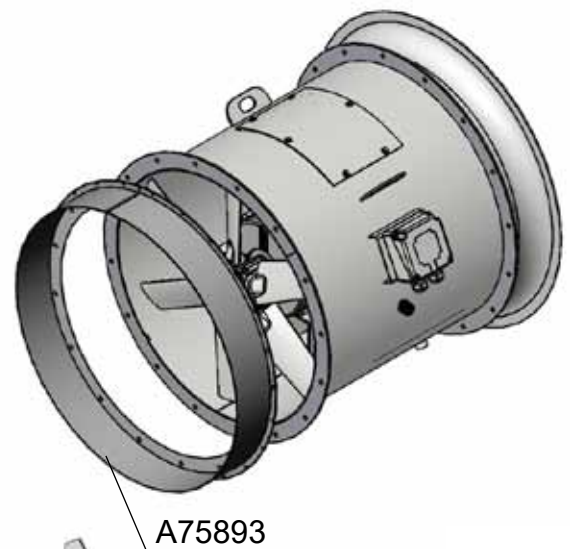
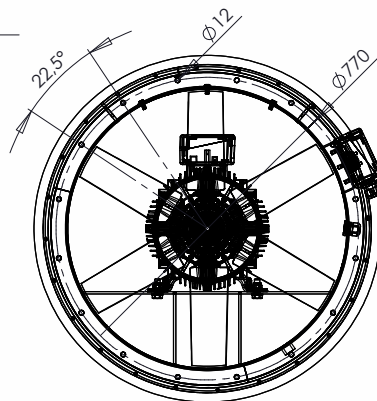
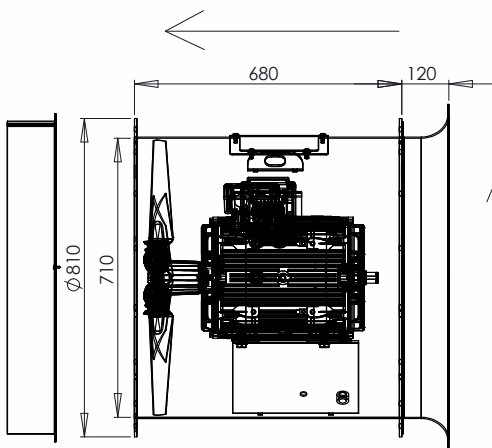

114556 Damper
- opens the fan airflow

114557 Instalation legs